

# Ultraaqua Autoclean

**Oil/water separator for compressed air condensate**

**Application:**

Everywhere, where legal supports for the disposal of compressor condensate exist. The Ultraaqua Autoclean UFA-AC is an oil/water separator for the purification of air compressor condensate and is particularly used with difficulty separable condensate e.g. an emulsion. The amounts of accumulating condensate can vary depending the place of installation and the season.

**Filtrate guarantee:**

The physical separation principle guarantees a filtrate quality of less than 5 mg/L to residual oil content\* in water, which is usually lower than the limit value that legally prescribed.

\* (measured acc. ISO 9377-2)

**Function:**

A pressure relief chamber separates condensate and expanding air. The condensate then passes a sedimentation compartment – easy to remove and therefore easy to clean. In order to get a maximum separation, free oil is prematurely rerouted via an overflow into a can. Two coalescence filter reduce the oil content of the condensate again, before it is filtered off after buffering in an internal tank in the actual process vessel. Oil and water are apart-filtered on reason of their different molecule sizes, i.e. oil molecules are held back, water molecules pass the filtration module. So prepared condensate can be introduced without further procedures into the public sewer net.

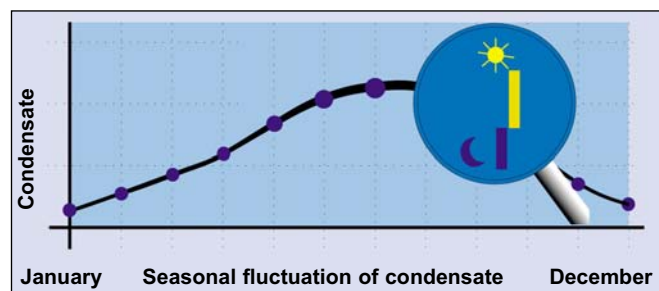
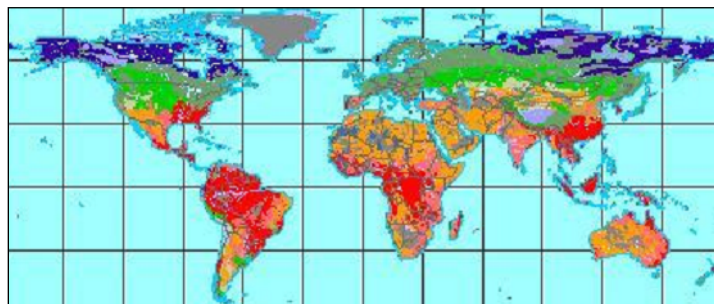

**Maintenance:**

Remaining maintenance work is emptying the oil reservoir and the refill of the cleaner. All other expirations were automated by the intelligent control. The LCD display indicates clear text information.

By the constant measurement of the current condensate entry the plant adapts automatically seasonal, production- or time of day-conditioned fluctuations. The most economical regeneration time of the filtration module is determined by an alignment of the condensate INPUT with the filtrate OUTPUT. The operating costs of the plant are minimized by the intelligent control.

## Ultraqua Autoclean

Features:	Benefits:
Autoclean	The comparison INPUT vs. OUTPUT extends the regeneration cycles. Thus the running costs of the unit are minimized. The automatic cleaning guarantees the longest service intervals for the user.
Programmable controller	Intelligent process control solution with high process security and best industry standard.
Network connection	To visualization and remote diagnostics for control stations etc. the controller is optionally expandable for Modbus, Profibus and Ethernet.
LCD display	Clear text messages make service and trouble shooting easy.
Process safety	By a thought out system the user will be informed in time, if a manual intervention is necessary, e.g. signaling via an potential free alarm contact for fault signals such as overflow alarm, defective sensors and much more.
Ceramic membrane	High thermal, mechanic and chemical resistance: 1 year service life guarantee!
All sealings made of VITON	Only VITON guarantees highest possible safety for condensate with its various ingredients.
Frost protection for the membrane	The operating temperature is continuously monitored, the heater starts automatically to ensure a minimum process temperature to protect the membrane from freezing conditions.

Performance data:			
Type	Output*	Compressor performance	
		Continental climate (kW)	Tropical climate (kW)
UFA-AC	max.		
0008	2.1 gal/ hr	90	45
0016	4.2 gal/ hr	160	90
0032	8.5 gal/ hr	315	160
0064	16.9 gal/ hr	710	315
0096	25.4 gal/ hr	1025	550
0128	33.8 gal/ hr	1420	710
0192	50.7 gal/ hr	2050	1100
0256	67.3 gal/ hr	2840	1420

\* dependent on used type of oil and its additives

Materials:	
Vessel	PP, <b>recyclable</b>
Filter/ demister	PUR-foam
Membrane	Ceramic
O-Rings, sealings	VITON
Process pump	Stainless steel
Valve block	Aluminium

Temperatures:	
Operating temperature	+34°F to +88°F
PH-range of the membrane:	1-14 to + 304°F

Optionen:	
Heater	Frost protection
Header tank	As buffer storage upstream of the plant at high irregular amount of condensate.
Oil resistant float switches	For the safety of a header tank or further external collecting vessels.
Pump header tank	230 V/ 50 Hz 115 V/ 60 Hz
Catch bains	To the overflow protection of the unit or a header tank, legally prescribed.
Network module	For the connection to an existing firm network (LAN) for the fast access of the unit status or fault signals.

Consumtion material:
Different cleaning agents

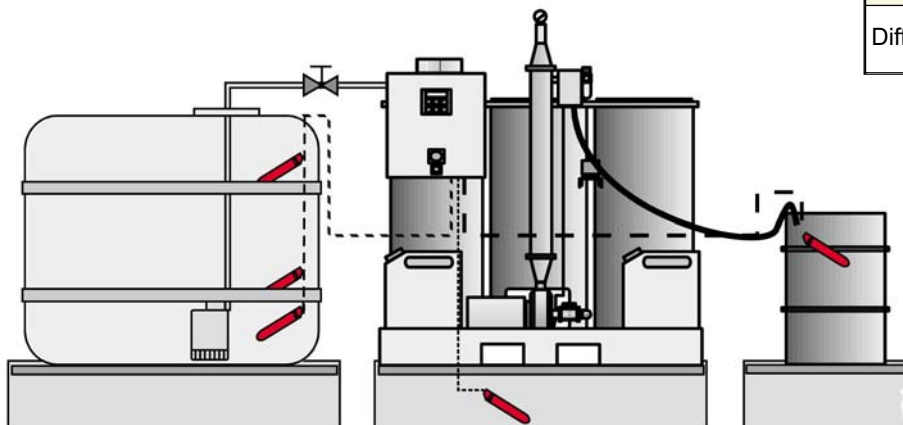

Example of a complete installation

## Ultraqua Autoclean

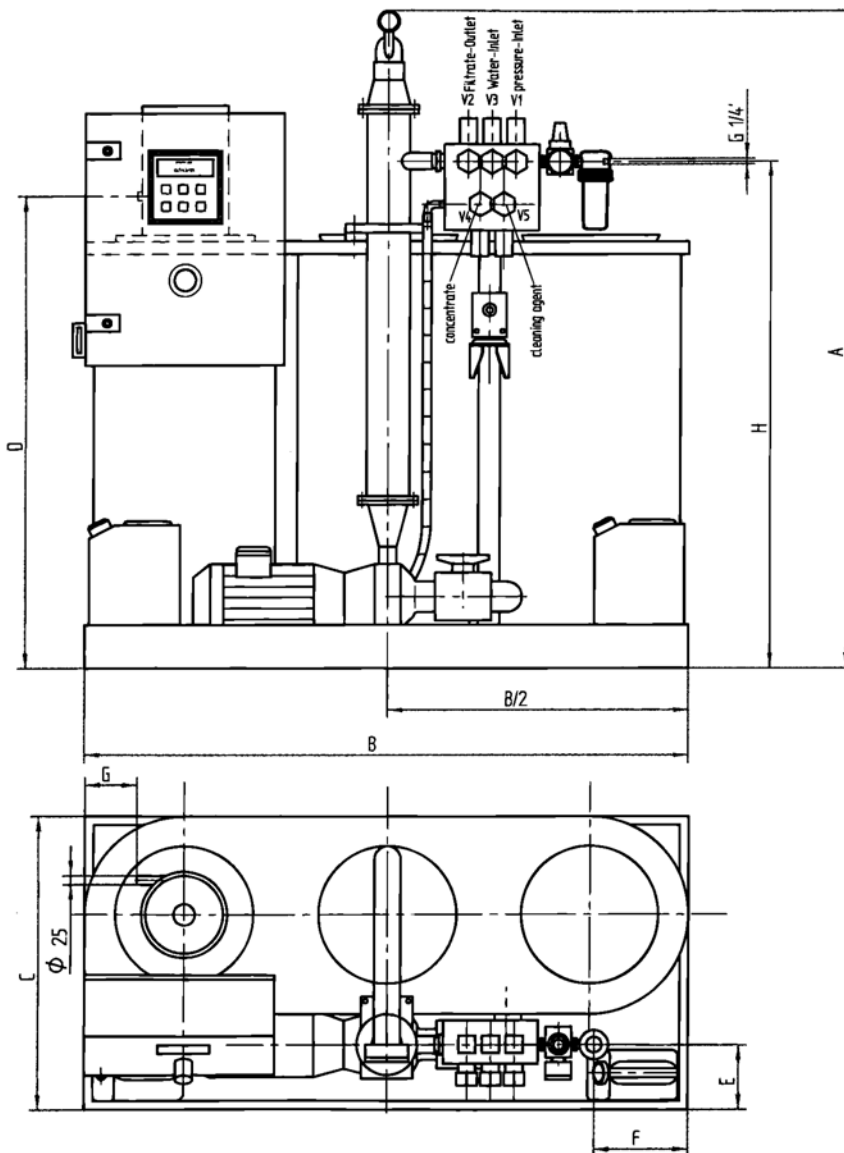

V1 = compressed air:

Pmin. = 80 psi;  
1/4" at filter

V2 = filtrate:

1/2" in valve block

V3 = water:

1/2" in valve block

V4 = concentrate:

3/8" in valve block

V5 = cleaning agent:

3/8" in valve block

Type	Dimensions					Volume	Electrical performance*
	A	B	C	D	G	Vessel	max.
	mm	mm	mm	mm	mm	gal	kW
0008	59.1	41.3	27.6	40.4	3.9	34.9	2.5
0016	59.1	41.3	27.6	40.4	3.9	34.9	2.5
0032	65.0	59.1	31.5	48.2	6.3	113.6	4.0
0064	68.9	59.1	31.5	48.2	6.3	113.6	1.6
0096	75.6	65.4	35.4	56.3	6.5	164.3	5.5
0128	78.7	72.4	37.8	60.2	7.9	223.7	7.0
0192	82.3	81.1	43.3	64.2	10.8	306.4	10.5
0256	86.2	90.6	47.2	70.9	12.6	438.5	15.0

\* 4 x 400 V/ 60 Hz, alternative 3 x 440 V/ 50 Hz available