



Typical Applications

- Process Water
- Waste Water
- Cooling Water
- Drinking Water
- Solvents
- Resins
- Paints
- Oils
- Coolants
- Chemicals

Industries Served

- Petro Chemicals
- Automotive
- Machining
- Plastic
- Food/Beverage
- Paint
- Printing
- Pulp & Paper
- Pharmaceutical
- Environmental

Features

- Accomodates No.2 bag, size 7" D x 32" OAL
- Continuous flow design up to 180 US gpm
- Standard 2" FNPT connection
- Side entry design
- Withstands 150 psig @ 225° F
- High capacity-low pressure drop
- Easy bag change-out
- Compact & Customizable design

Options

- 2 1/2" and 3" connection available in NPT Male/Female or flange housing
- Available in Carbon Steel, 304 Stainless Steel and 316 Stainless Steel
- Adjustable robust tripod stand design
- Displacement balloon for low product loss and quick bag replacement
- Backflush restrainer to prevent bag rupture due to shock loading.

SAMPSON Filter Vessels provide an economical solution to a variety of filtration needs. Its cost-effective compact design and the connection possibilities allows easy installation and maintenance in any configuration. SAMPSON Filter Vessels are constructed in the highest quality material and standards which allows us to fully guarantee our products' performance which provides you with consistent reliability year after year.



- Efficient
- Durable
- Available from Stock

Tel: 514-326-8852
Fax: 514-326-8961

Environmental
Remediation
Equipment Inc.
8529 Lafrenaie
Montréal, Québec
Canada, H1P 2B3
Web:
www.ereinc.com
email:
sales@ereinc.com

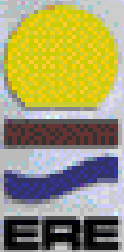



ERS-180

TOP ENTRY



| FITTING SIZE | A | B | C | D | E |
|--------------|--------|--------|--------|-------|----------|
| 2" FNPT | 29-1/4 | 9 | 10-1/4 | 4-5/8 | 15-7/8 |
| 2-1/2" FNPT | 29-1/4 | 11 | 10-1/4 | 4-5/8 | 17 |
| 3" FNPT | 29-1/4 | 12-3/4 | 10-1/4 | 4-5/8 | 18-11/16 |

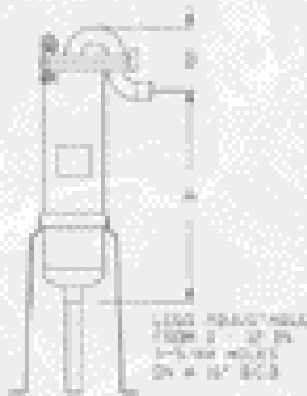

SIDE ENTRY

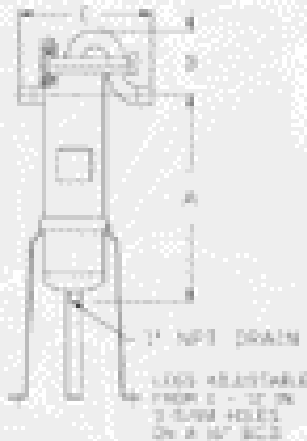

OPTIONS



DISPLACEMENT BALLOON

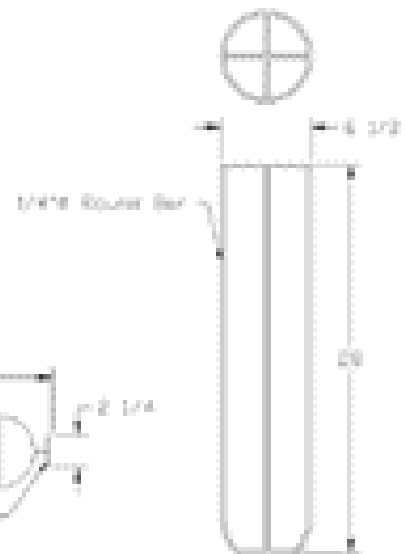

BACKFLUSH RESTRAINER

| FITTING SIZE | A | B | C | D | E |
|--------------|--------|--------|--------|-------|--------|
| 2" FNPT | 29-1/4 | 9 | 10-1/4 | 4-5/8 | 17-1/2 |
| 2-1/2" FNPT | 29-1/4 | 11 | 10-1/4 | 4-5/8 | 18-5/8 |
| 3" FNPT | 29-1/4 | 12-3/4 | 10-1/4 | 4-5/8 | 20-1/4 |

SHIPPING WEIGHT
VOLUME
DESIGN PRESSURE

110 lbs.
7-1/4 US. gal.
150 psig. @ 225 °F